

Q3R(A,C) Series

Single Packaged Heat Pump, Single Phase

Q3RA-10 SEER
2 thru 5 Ton Units

Cooling: 24,000 to 58,000 Btuh
Heating: 23,200 to 58,000 Btuh

Q3RC-12 SEER
2 Ton thru 4 Ton Units

Cooling: 23,800 to 47,000 Btuh
Heating: 23,400 to 47,000 Btuh

The Q3 Series single packaged heat pumps are high efficiency self contained cooling and heating units that can be installed on a slab. Units are ETL and ETLc listed. The unit is truly designed with the contractor and the consumer in mind.

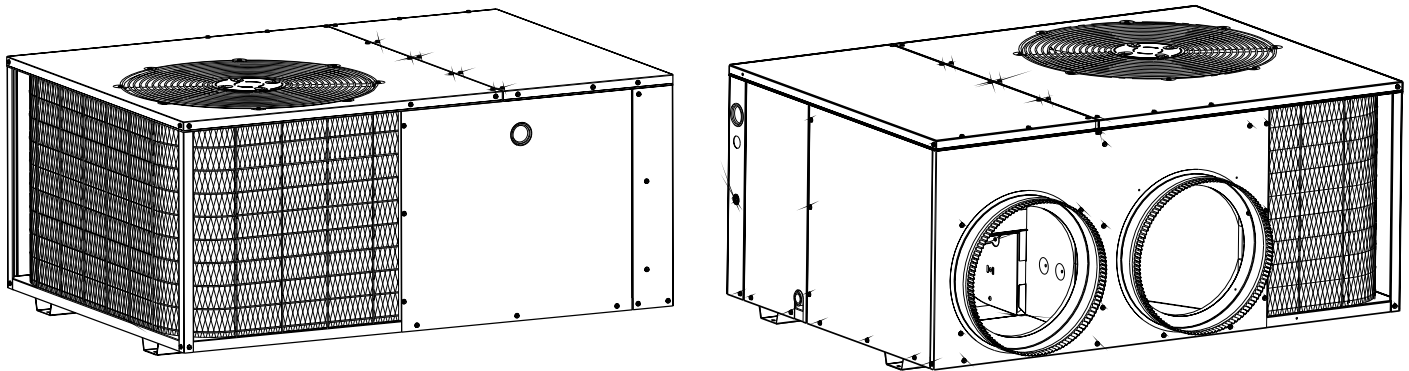

FEATURES AND BENEFITS

- **State-of-the-art compressor** is standard equipment.
- **Designed using galvanized steel** with a polyester urethane coat finish. The 950 hour salt spray finish resists corrosion 50% better than comparable units.
- **Both indoor and outdoor coils** are designed to optimize heat transfer, minimize size and cost, and increase durability and reliability.
- **A heavy duty PSC motor** for long lasting reliability and operation. Requires no maintenance and is completely protected from rain and snow.
- **The service valves are easily accessible** and simplify servicing of the refrigeration system.
- **A wire coil guard and mesh hail guard that will never rust** protects the coil from being damaged by balls, lawnmowers, hail, etc.
- **Designed to make servicing easier** for the contractor, access panels are provided to all major components and the compressor.
- **1" clearance** to combustibles on duct side of the unit allows for installations in tight areas.
- **Easy access** to evaporator for cleaning and general maintenance.
- **Drain trap** design optimizes drainage capabilities.
- **Easy to install** electric heat strip provides up to 20 kw of heat output.
- **Compact footprint and profile** make the Q3 Series easy to install and transport.
- **Outdoor thermostat** is standard equipment on all heat pumps.
- **8 Year Residential Parts Warranty and 5 Year Quality Pledge** is the best warranty in the business. Extended labor protection plans are available.
- **One Year Commercial Parts Warranty**

MODEL IDENTIFICATION CODE

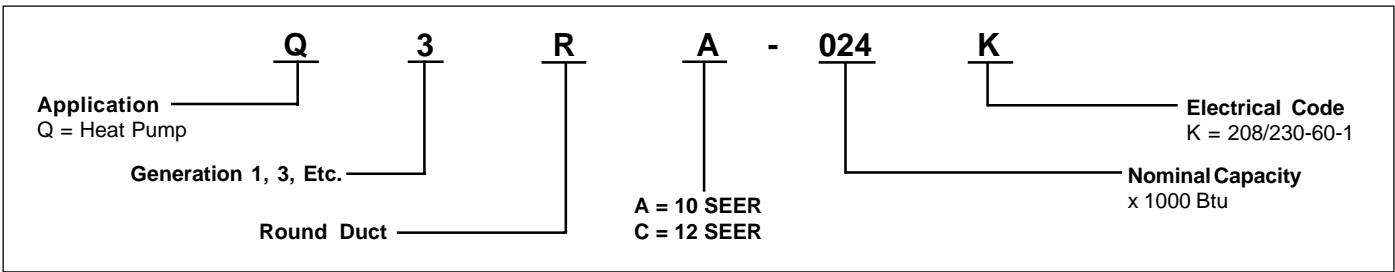

DIMENSIONS

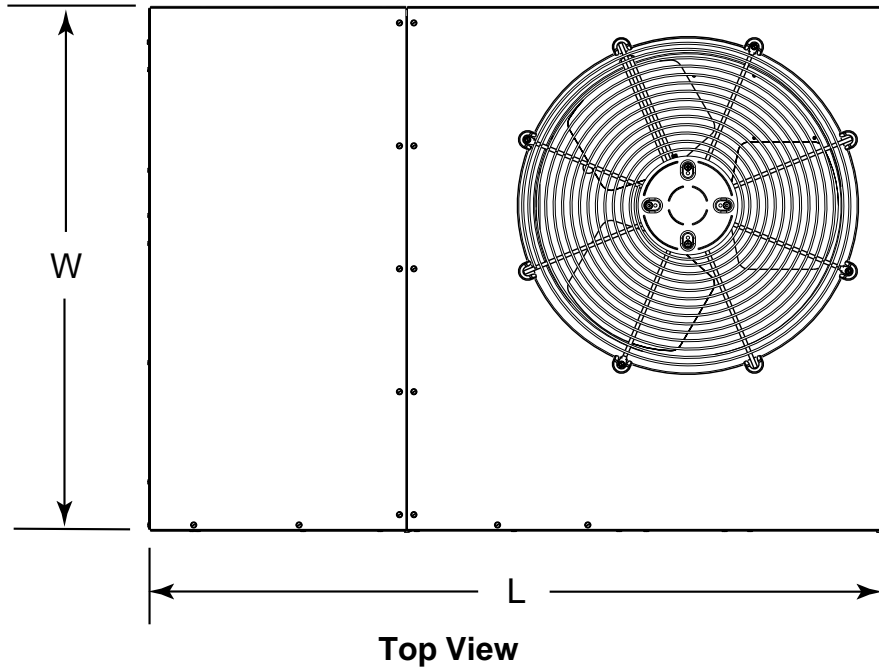

Model Number	(L) Length	(W) Width	(H) Height	A	B
Q3RA-					
024K	49	35	22.2	40.15	7.61
030K	49	35	22.2	35.02	2.48
036K	49	35	22.2	35.02	2.48
042K	49	35	30.2	35.02	2.48
048K	49	35	30.2	40.15	7.61
060K	49	35	30.2	35.02	2.48
Q3RC-					
024K	49	35	22.2	40.15	7.61
030K	49	35	22.2	40.15	7.61
036K	49	35	30.2	40.15	7.61
042K	49	35	30.2	40.15	7.61
048K	49	35	30.2	35.02	2.48

DIMENSIONS Continued

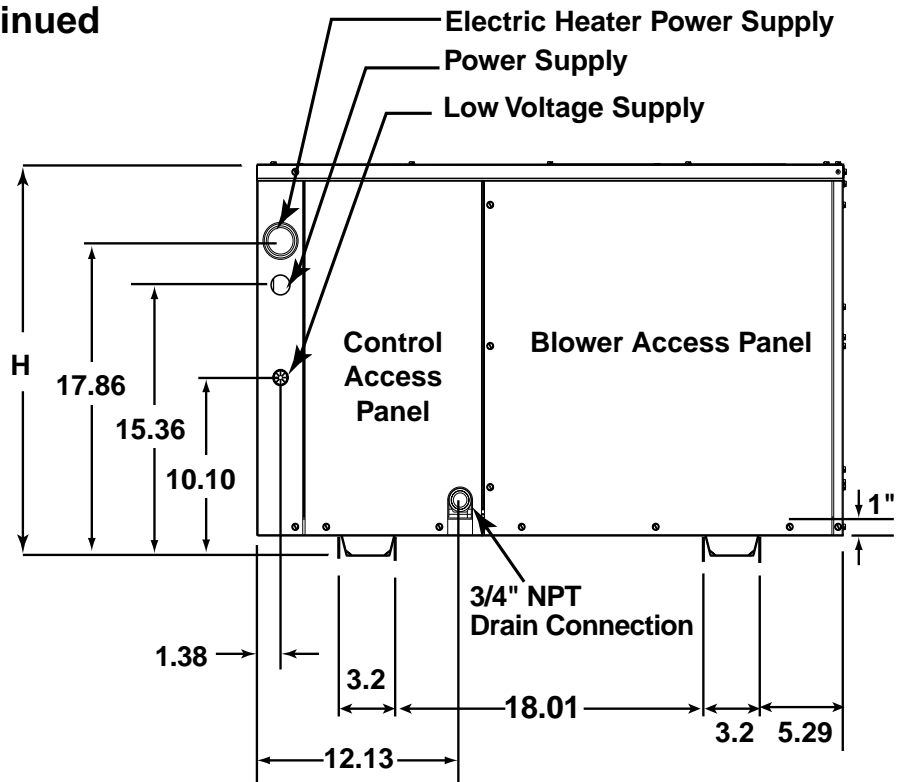

Side View

Model Number	Return Diameter (in)
Q3RA-	
024K	12
030K	12
036K	12
042K	14
048K	14
060K	14

Model Number	Return Diameter (in)
Q3RC-	
024K	12
030K	12
036K	14
042K	14
048K	14

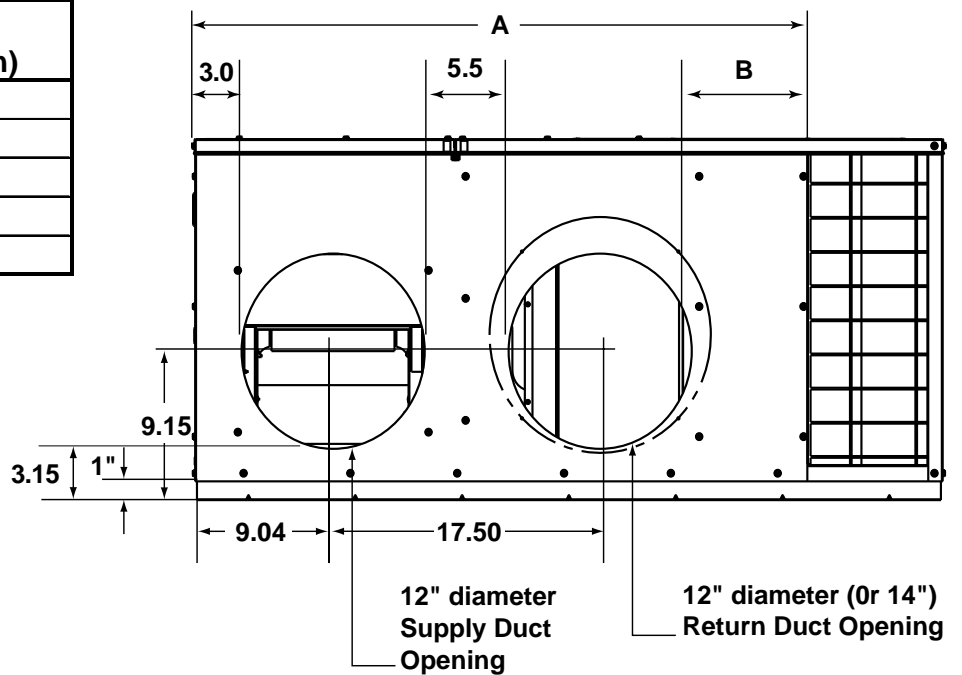

Back (Duct) View

PHYSICAL SPECIFICATIONS

Q3RA Models

Model No. Q3RA-	024K	030K	036K	042K	048K	060K
Electric Rating — 60 Hz (a)						
Operating Voltage Range	187 - 253	187 - 253	187 - 253	187 - 253	187 - 253	187 - 253
Min. Circuit Ampacity (a)	14.9	20.4	21.8	25.8	31.6	38.1
Field Wire Size — AWG (a)	14	10	10	10	8	8
Delay Fuse — Max. (b)	20	30	35	40	50	60
Total Unit — AMPS	12.4	17.0	18.2	20.4	26.1	31.3
Compressor						
Volts	208 - 230	208 - 230	208 - 230	208 - 230	208 - 230	208 - 230
Rated Load Amps	9.8	13.7	14.8	17.0	21.8	27.0
Lock Rotor Amps	56.0	75.0	96.0	105.0	131.0	144.0
Fan Motor and Condenser						
Fan Motor — HP - RPM	1/4 - 1100	1/4 - 1100	1/3 - 1100	1/3 - 1100	1/3 - 1100	1/3 - 1100
Fan Motor — Amps	1.2	1.2	1.3	1.3	1.3	1.3
Fan Dia. — CFM	20" - 2700	20" - 2700	20" - 2700	20" - 3000	20" - 3000	20" - 3000
Motor and Evaporator						
Blower Motor — HP - RPM	1/4 - 980	1/3 - 1080	1/3 - 900	1/3 - 900	1/2 - 1000	1/2 - 1000
Blower Motor — Amps	1.4	2.1	2.1	2.1	3	3
CFM @ E.S.P. — in. W.C.	1000 @ .30	1320 @ .30	1390 @ .30	1390 @ .30	1730 @ .30	1680 @ .30
Refrigerant — Oz.	60	80	80	100	102	132
Shipping Weight -- Lbs.	280	295	300	340	355	390

Q3RC Models

Model No. Q3RC-	024K	030K	036K	042K	048K
Electric Rating — 60 Hz (a)					
Operating Voltage Range	187 - 253	187 - 253	187 - 253	187 - 253	187 - 253
Min. Circuit Ampacity (a)	15.4	20.1	21.8	22.7	28.3
Field Wire Size — AWG (a)	12	10	10	10	10
Delay Fuse — Max. (b)	25	30	35	35	45
Total Unit — AMPS	12.8	16.7	18.1	21.3	28.0
Compressor					
Volts	208 - 230	208 - 230	208 - 230	208 - 230	208 - 230
Rated Load Amps	10.2	13.4	14.7	17.9	23.7
Lock Rotor Amps	56.0	72.5	83.0	104.0	129.0
Fan Motor and Condenser					
Fan Motor — HP - RPM	1/4 - 1125	1/4 - 1125	1/3 - 1100	1/3 - 1100	1/3 - 1100
Fan Motor — Amps	1.2	1.2	1.3	1.3	1.3
Fan Dia. — CFM	20" - 2700	20" - 2700	20" - 2700	20" - 3000	20" - 3000
Motor and Evaporator					
Blower Motor — HP - RPM	1/4 - 980	1/3 - 1080	1/3 - 900	1/3 - 900	1/2 - 1000
Blower Motor — Amps	1.4	2.1	2.1	2.1	3
CFM @ E.S.P. — in. W.C.	1000 @ .30	1320 @ .30	1390 @ .30	1390 @ .30	1730 @ .30
Refrigerant — Oz.	80	98	104	104	140
Shipping Weight -- Lbs.	285	300	345	350	385

(a) Amperage and wire size based on refrigeration system only with 60° C wire, 50 ft. length. See Electrical Data tables for supplemental electric heaters. Refer to National Electric Code for additional derating factors for field installed conductors.

(b) Use time delay fuse or "HACR" type circuit breaker.

ELECTRICAL DATA

Model Number	Heater Installed Norm. KW	Single Supply Circuit Option										Multiple Supply Circuit Option											
		Circuit A					Circuit B					Circuit A					Circuit B						
		Minimum Circuit Amp.	Rec Wire Gauge (60°C Cu)	Rec Wire Gauge (75°C Cu)	Rec Wire Gauge (90°C Cu)	Maximum Over-current Rating*	Minimum Circuit Amp.	Rec Wire Gauge (60°C Cu)	Rec Wire Gauge (75°C Cu)	Rec Wire Gauge (90°C Cu)	Maximum Over-current Rating*	Minimum Circuit Amp.	Rec Wire Gauge (60°C Cu)	Rec Wire Gauge (75°C Cu)	Rec Wire Gauge (90°C Cu)	Maximum Over-current Rating	Minimum Circuit Amp.	Rec Wire Gauge (60°C Cu)	Rec Wire Gauge (75°C Cu)	Rec Wire Gauge (90°C Cu)	Maximum Over-current Rating		
Q3RA-024K	0	14.9	14	14	20	-	-	-	-	-	-	-	-	-	-	-	-	-	-	-			
	5	39.9	8	8	40	-	-	-	-	-	-	-	-	-	-	-	-	-	-	-			
	8	54.4	6	6	60	-	-	-	-	-	-	-	-	-	-	-	-	-	-	-			
Q3RA-030K	0	64.9	4	6	70	13.5	14	14	14	20	51.4	6	6	8	60	-	-	-	-	-			
	5	45.4	6	8	50	-	-	-	-	-	-	-	-	-	-	-	-	-	-	-			
	8	60.0	4	6	60	-	-	-	-	-	-	-	-	-	-	-	-	-	-	-			
Q3RA-036K	0	70.4	3	4	80	18.3	12	12	12	30	52.1	6	6	8	60	52.1	6	6	8	60			
	5	95.4	1	3	100	43.3	6	8	8	30	27.1	10	10	10	30	52.1	6	6	8	60			
	15 (3 circuit)	-	-	-	-	18.3	12	12	12	30	27.1	10	10	10	30	52.1	6	6	8	60			
Q3RA-042K	0	21.8	10	10	35	-	-	-	-	-	-	-	-	-	-	-	-	-	-	-			
	5	46.8	6	8	50	-	-	-	-	-	-	-	-	-	-	-	-	-	-	-			
	8	61.4	4	6	60	-	-	-	-	-	-	-	-	-	-	-	-	-	-	-			
Q3RA-048K	0	71.8	3	4	80	19.7	12	12	12	30	52.1	6	6	8	60	52.1	6	6	8	60			
	5	96.8	1	3	100	44.7	6	8	8	50	27.1	10	10	10	30	52.1	6	6	8	60			
	15 (3 circuit)	-	-	-	-	19.7	12	12	12	30	27.1	10	10	10	30	52.1	6	6	8	60			
Q3RA-060K	0	25.8	10	10	40	-	-	-	-	-	-	-	-	-	-	-	-	-	-	-			
	5	50.8	6	8	60	23.7	10	10	10	40	41.7	6	8	8	45	41.7	6	8	8	45			
	8	65.4	4	4	70	23.7	10	10	10	40	52.1	6	6	8	60	52.1	6	6	8	60			
Q3RC-024K	0	75.8	3	4	110	48.7	6	8	8	60	52.1	6	6	8	60	52.1	6	6	8	60			
	5	100.8	1	2	130	23.7	10	10	10	40	30.2	8	8	8	35	30.2	8	8	8	35			
	15 (3 circuit)	-	-	-	-	23.7	10	10	10	40	52.1	6	6	8	60	52.1	6	6	8	60			
Q3RC-030K	0	125.8	0	1	150	23.7	10	10	10	40	52.1	6	6	8	60	52.1	6	6	8	60			
	5	31.6	8	8	50	-	-	-	-	-	-	-	-	-	-	-	-	-	-	-			
	8	56.6	4	6	60	28.6	10	10	10	50	29.3	10	10	10	30	29.3	10	10	10	30			
Q3RC-036K	0	71.1	3	4	80	28.6	10	10	10	50	43.9	6	8	8	45	43.9	6	8	8	45			
	5	81.6	3	4	90	28.6	10	10	10	50	54.3	6	6	8	60	54.3	6	6	8	60			
	10	106.6	1	2	110	28.6	10	10	10	50	28	10	10	10	30	28	10	10	10	30			
Q3RC-042K	0	132	0	1	150	28.6	10	10	10	50	53	6	6	8	60	53	6	6	8	60			
	5	38.1	8	8	60	-	-	-	-	-	-	-	-	-	-	-	-	-	-	-			
	8	63.1	4	6	70	35.1	8	8	8	60	29.3	10	10	10	30	29.3	10	10	10	30			
Q3RC-048K	0	77.6	3	4	80	35.1	8	8	8	60	43.9	6	8	8	45	43.9	6	8	8	45			
	5	88.1	2	3	100	35.1	8	8	8	60	54.3	6	6	8	60	54.3	6	6	8	60			
	10	113.1	0	2	125	35.1	8	8	8	60	28	10	10	10	30	28	10	10	10	30			
Q3RC-060K	0	138	0	1	150	35.1	8	8	8	60	53	6	6	8	60	53	6	6	8	60			
	5	15.4	12	12	25	-	-	-	-	-	-	-	-	-	-	-	-	-	-	-			
	8	40.4	6	8	45	-	-	-	-	-	-	-	-	-	-	-	-	-	-	-			
Q3RC-084K	0	54.9	6	6	60	-	-	-	-	-	-	-	-	-	-	-	-	-	-	-			
	5	65.4	4	6	70	14	14	14	14	20	51.1	6	6	8	60	51.1	6	6	8	60			
	10	20.1	10	10	30	-	-	-	-	-	-	-	-	-	-	-	-	-	-	-			
Q3RC-096K	0	45.1	6	8	50	-	-	-	-	-	-	-	-	-	-	-	-	-	-	-			
	5	59.6	4	6	60	-	-	-	-	-	-	-	-	-	-	-	-	-	-	-			
	8	70.1	3	4	80	18	12	12	12	30	52.1	6	6	8	60	52.1	6	6	8	60			
Q3RC-108K	0	70.1	3	4	80	18	12	12	12	30	52.1	6	6	8	60	52.1	6	6	8	60			
	5	95.1	1	3	100	43.3	6	8	8	50	27.1	10	10	10	30	27.1	10	10	10	30			
	15 (3 circuit)	-	-	-	-	18	12	12	12	30	27.1	10	10	10	30	27.1	10	10	10	30			
Q3RC-120K	0	21.8	10	10	35	-	-	-	-	-	-	-	-	-	-	-	-	-	-	-			
	5	46.8	6	8	50	-	-	-	-	-	-	-	-	-	-	-	-	-	-	-			
	8	61.4	4	6	60	19.7	12	12	12	30	41.7	6	8	8	45	41.7	6	8	8	45			
Q3RC-144K	0	71.8	3	4	80	19.7	12	12	12	30	52.1	6	6	8	60	52.1	6	6	8	60			
	5	97.7	1	3	100	45.6	6	8	8	50	27.1	10	10	10	30	27.1	10	10	10	30			
	15 (3 circuit)	-	-	-	-	20.6	10	10	10	35	30.2	8	8	8	35	30.2	8	8	8	35			
Q3RC-180K	0	28.3	10	10	45	20.6	10	10	10	40	25.3	10	10	10	40	25.3	10	10	10	40			
	5	53.3	6	8	60	20.6	10	10	10	40	25.3	10	10	10	40	25.3	10	10	10	40			
	8	67.9	4	6	70	20.6	10	10	10	40	25.3	10	10	10	40	25.3	10	10	10	40			
Q3RC-240K	0	78.3	3	4	80	50.3	6	8	8	60	53	6	6	8	60	53	6	6	8	60			
	5	103.3	1	2	110	25.3	10	10	10	40	28	10	10	10	30	28	10	10	10	30			
	15 (3 circuit)	-	-	-	-	25.3	10	10	10	40	53	6	6	8	60	53	6	6	8	60			
Q3RC-300K	0	128	0	1	150	25.3	10	10	10	40	53	6	6	8	60	53	6	6	8	60			
	5	31.6	8	8	50	-	-	-	-	-	-	-	-	-	-	-	-	-	-	-			
	8	56.6	4	6	60	28.6	10	10	10	50	29.3	10	10	10	30	29.3	10	10	10	30			
Q3RC-360K	0	71.1	3	4	80	28.6	10	10	10	50	43.9	6	8	8	45	43.9	6	8	8	45			
	5	81.6	3	4	90	28.6	10	10	10	50	54.3	6	6	8	60	54.3	6	6	8	60			
	10	106.6	1	2	110	28.6	10	10	10	50	28	10	10	10	30	28	10	10	10	30			
Q3RC-480K	0	132	0	1	150	28.6	10	10	10	50	53	6	6	8	60	53	6	6	8	60			
	5	38.1	8	8	60	-	-	-	-	-	-	-	-	-	-	-	-	-	-	-			
	8	63.1	4	6	70	35.1	8	8	8	60	29.3	10	10	10	30	29.3	10	10	10	30			
Q3RC-600K	0	77.6	3	4	80	35.1	8	8	8	60	43.9	6	8	8	45	43.9	6	8	8	45			
	5	88.1	2	3	100	35.1	8	8	8	60	54.3	6	6	8	60	54.3	6	6	8	60			
	10	113.1	0	2	125	35.1	8	8	8	60	28	10	10	10	30	28	10	10	10	30			
Q3RC-720K	0	138	0	1	150	35.1	8	8	8	60	53	6	6	8	60	53	6	6	8	60			
	5	15.4	12	12	25	-	-	-	-	-	-	-	-	-	-	-	-	-	-	-			
	8	40.4	6	8	45	-	-	-	-	-	-	-	-	-	-	-	-	-	-	-			
Q3RC-960K	0	54.9	6	6	60	-	-	-	-	-	-	-	-	-	-	-	-	-	-	-			
	5	65.4	4	6	70	14	14	14	14	20	51.1	6	6	8	60	51.1	6	6	8	60			
	10	20.1	10	10	30	-	-	-	-	-	-	-	-	-	-	-	-	-	-	-			
Q3RC-1200K	0	45.1	6	8	50	-	-	-	-	-	-	-	-	-	-	-	-	-	-	-			
	5	59.6	4	6	60	-	-	-	-	-	-	-	-	-	-	-	-	-	-	-			
	8	70.1	3	4	80	18	12	12	12	30	52.1	6	6	8	60	52.1	6	6	8	60			
Q3RC-1600K	0	70.1	3	4	80	18	12	12	12	30	52.1	6	6	8	60	52.1	6	6	8	60			
	5	95.1	1	3	100	43.3	6	8	8	50	27.1	10	10	10	30	27.1	10	10	10	30			
	15 (3 circuit)	-	-	-	-	18	12	12	12	30	27.1	10	10	10	30	27.1	10	10	10	30			
Q3RC-2000K	0	21.8	10	10	35	-	-	-	-	-	-	-	-	-	-	-	-	-	-	-			
	5	46.8	6	8	50	-	-	-	-	-	-	-	-	-	-	-	-	-	-	-			
	8	61.4	4	6	60	19.7	12	12	12	30	41.7	6	8	8	45	41.7	6	8	8	45			
Q3RC-2700K	0	71.8	3	4	80	19.7	12	12	12	30	52.1	6	6	8	60	52.1	6	6	8	60			
	5	97.7	1	3	100	45.6	6	8	8	50	27.1	10	10	10	30	27.1	10	10	10	30			
	15 (3 circuit)	-	-	-	-	20.6	10	10	10														

SYSTEM HEATING AND COOLING CAPACITIES

Model Number Q3RA-	Cooling Btuh	SEER	Heating Btuh @ 47	HSPF
024K	24,000	10	23,000	6.8
030K	30,000	10	28,400	6.8
036K	34,400	10	33,200	6.8
042K	40,500	10	40,500	6.8
048K	47,000	10	46,500	6.8
060K	58,000	10	58,000	6.8

Model Number Q3RC-	Cooling Btuh	SEER	Heating Btuh @ 47	HSPF
024K	23,800	12	23,400	7.0
030K	30,000	12	27,200	7.0
036K	35,000	12	34,000	7.0
042K	42,000	12	40,500	7.0
048K	47,000	12	47,500	7.0

BLOWER PERFORMANCE

Model Number Q3RA-		External Static Pressure (in. WC)					
		0.1	0.2	0.3	0.4	0.5	0.6
024K	High	1120	1060	1000	930	860	750
	Low	840	800	760	710	610	N/A
030K	High	1450	1380	1320	1240	1150	1050
	Low	1070	1050	1030	980	930	N/A
036K	High	1480	1440	1390	1330	1270	1190
	Low	1270	1230	1190	1140	1080	1000
042K	High	1480	1430	1390	1330	1270	1190
	Low	1270	1220	1180	1140	1080	1010
048K	High	1840	1780	1730	1650	1580	1500
	Low	1700	1650	1590	1540	1470	1390
060K	High	1800	1740	1680	1620	1540	1470
	Low	1660	1610	1560	1500	1430	1360

Model Number Q3RC-		External Static Pressure (in. WC)					
		0.1	0.2	0.3	0.4	0.5	0.6
024K	High	1120	1060	1000	930	860	750
	Low	840	800	760	710	610	N/A
030K	High	1450	1380	1320	1240	1150	1050
	Low	1070	1050	1030	980	930	N/A
036K	High	1480	1440	1390	1330	1270	1190
	Low	1270	1230	1190	1140	1080	1000
042K	High	1480	1430	1390	1330	1270	1190
	Low	1270	1220	1180	1140	1080	1010
048K	High	1840	1780	1730	1650	1580	1500
	Low	1700	1650	1590	1540	1470	1390

COPPER WIRE SIZE — AWG (1% Voltage Drop)				
Supply Wire Length-Feet				Supply Circuit Ampacity
200	150	100	50	
6	8	10	14	15
4	6	8	12	20
4	6	8	10	25
4	4	6	10	30
3	4	6	8	35
3	4	6	8	40
2	3	4	6	45
2	3	4	6	50

Wire Size based on N.E.C. for 60° type copper conductors.

ACCESSORIES

Heater Application Matrix

Model Number Q3RA-	Motor Speed	H3HK-005H-01A 917166A	H3HK-008H-01A 917167A	H3HK-010H-01A 917168A	H3HK-015H-01A 917169A	H3HK-020H-01A 917170A	H3HK-015H-21A 917172A	H3HK-020H-21A 917173A
024K	High	X(0)	X(0)	X(2)	NA	NA	NA	NA
	Low	X(0)	X(0)	X(2)	NA	NA	NA	NA
030K	High	X(0)	X(0)	X(2)	X(2 or 3)	NA	X(0 or 1)	NA
	Low	X(0)	X(0)	X(2)	X(2 or 3)	NA	X(0 or 1)	NA
036K	High	X(0)	X(0)	X(2)	X(2 or 3)	NA	X(0 or 1)	NA
	Low	X(0)	X(0)	X(2)	X(2 or 3)	NA	X(0 or 1)	NA
042K	High	X(0)	X(2)	X(2)	X(2 or 3)	X(3)	X(0 or 1)	X(1)
	Low	X(0)	X(2)	X(2)	X(2 or 3)	NA	X(0 or 1)	NA
048K	High	X(2)	X(2)	X(2)	X(2 or 3)	X(3)	X(0 or 1)	X(1)
	Low	X(2)	X(2)	X(2)	X(2 or 3)	NA	X(0 or 1)	NA
060K	High	X(2)	X(2)	X(2)	X(2 or 3)	X(3)	X(0 or 1)	X(1)
	Low	X(2)	X(2)	X(2)	X(2 or 3)	NA	X(0 or 1)	NA

Model Number Q3RC-	Motor Speed	H3HK-005H-01A 917166A	H3HK-008H-01A 917167A	H3HK-010H-01A 917168A	H3HK-015H-01A 917169A	H3HK-020H-01A 917170A	H3HK-015H-21A 917172A	H3HK-020H-21A 917173A
024K	High	X(0)	X(0)	X(2)	NA	NA	NA	NA
	Low	X(0)	X(0)	X(2)	NA	NA	NA	NA
030K	High	X(0)	X(0)	X(2)	X(2 or 3)	NA	X(0 or 1)	NA
	Low	X(0)	X(0)	X(2)	X(2 or 3)	NA	X(0 or 1)	NA
036K	High	X(0)	X(0)	X(2)	X(2 or 3)	NA	X(0 or 1)	NA
	Low	X(0)	X(0)	X(2)	X(2 or 3)	NA	X(0 or 1)	NA
042K	High	X(0)	X(2)	X(2)	X(2 or 3)	X(3)	X(0 or 1)	X(1)
	Low	X(0)	X(2)	X(2)	X(2 or 3)	NA	X(0 or 1)	NA
048K	High	X(2)	X(2)	X(2)	X(2 or 3)	X(3)	X(0 or 1)	X(1)
	Low	X(2)	X(2)	X(2)	X(2 or 3)	NA	X(0 or 1)	NA

NA = Not Approved

() = Number of internal circuit breaker kits required.

Heater Kit Accessories

Description	Part Number
4-Pole single circuit adaptor	913350
6-Pole single circuit adaptor	913556
Circuit Breaker Single Phase (2-pole)	913554



CERTIFICATION APPLIES ONLY WHEN THE COMPLETE SYSTEM IS LISTED WITH ARI

We Encourage Professionalism



Through Technician Certification by NATE

958A-0802 (Replaces 958A-0502)

Before purchasing this appliance, read important energy cost and efficiency information available from your retailer. Specifications and illustrations subject to change without notice and without incurring obligations. Printed in U.S.A. (08/02)

O'Fallon, MO

NORDYNE