

Q4SD Series

Single Packaged Heat Pump, Single Phase

Q4SD-13 SEER

2 - 5 Ton Units

Cooling: 24,000 to 55,500 Btuh

Heating: 22,000 to 51,000 Btuh

The Q4SD Series single packaged heat pumps are high efficiency self contained cooling and heating units that can be installed on a roof or on a slab. The convertible unit design makes installations simple in all applications. Units are ETL and ETLc listed. The unit is truly designed with the contractor and the consumer in mind.

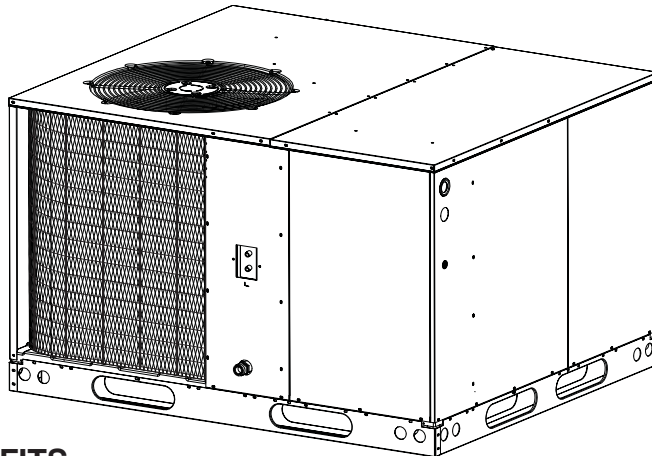

FEATURES AND BENEFITS

- **Compact Footprint/Low Profile**
Easy to handle and transport.
- **Heavy-Gauge, Full Perimeter Base Rails**
Facilitates forklift handling and curb mounting.
- **Convertible Air Delivery**
Horizontal or downflow to accommodate rooftop or horizontal application.
- **Galvanized Steel Cabinet**
Polyurethane finish provides 950 hours salt spray protection.
- **Plastic Coated Coil Guard and Mesh Hail Guard**
Will never rust and protects the coil from being damaged by balls, lawnmowers, hail etc.
- **Access to Controls and Major Components**
Easy in and out service.
- **Externally Accessible Service Ports**
Quick access to refrigerant system without disrupting operation.
- **Corrosion-Resistant Drain Pan**
Quickly drains away evaporator condensate.
- **Service Access Panels**
Allows easy access to all major components and the compressor. Designed to make servicing easier for the Contractor.
- **Easy to Install**
Electric heat strip provides up to 20 KW of heat output.
- **Proven, Industry Standard Components**
Easier service and availability.
- **ECM Variable Speed Motor**
Advanced technology allows the motor to automatically adjust to different static loads. The variable speed motor allows for extra quiet operation and improved air quality.
- **Quiet Operation and Low Vibration**
20" fan blade combined with custom venturi condenser fan.
- **8 Year Residential Parts Warranty and 5 Year Quality Pledge**
The best warranty in the business. Extended labor protection plans are available.
- **One Year Commercial Parts Warranty**

MODEL IDENTIFICATION CODE

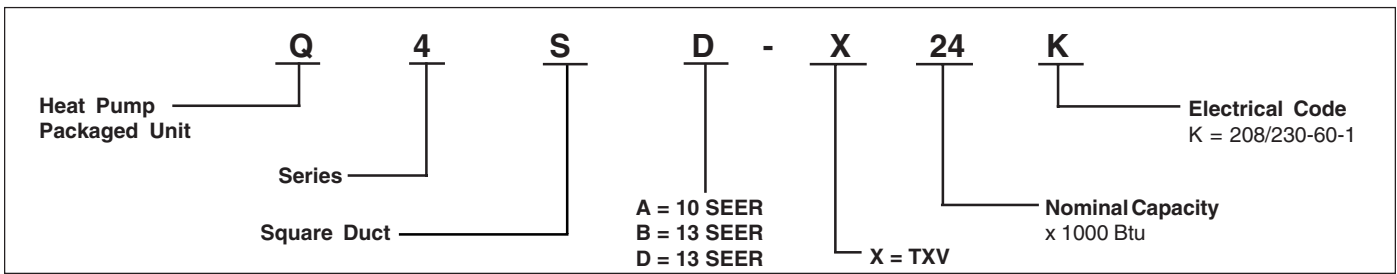

DIMENSIONS

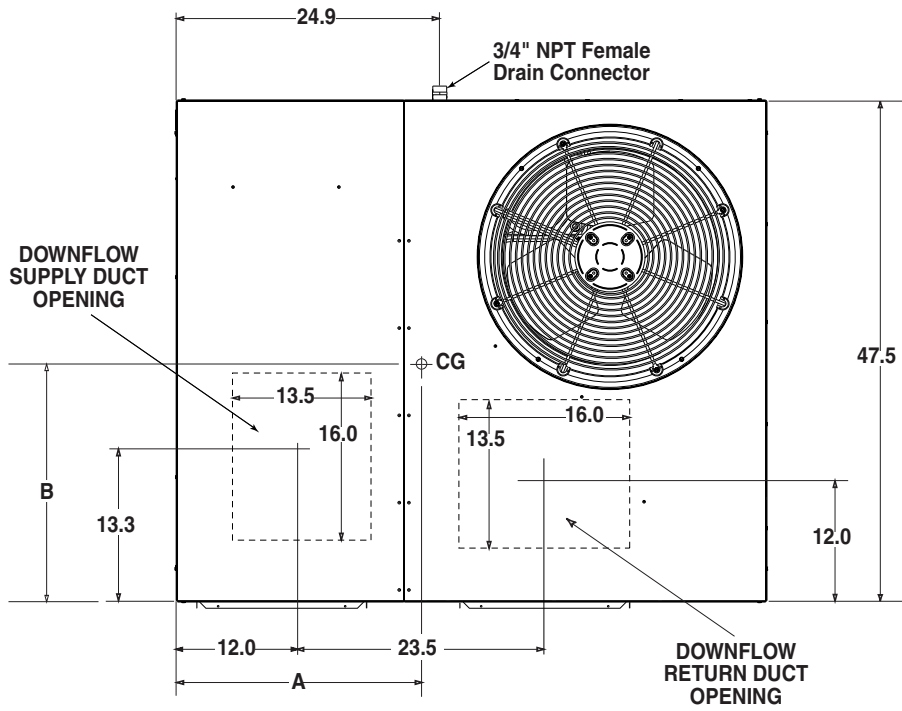

Top View

Model Number	Unit Weight	Center of Gravity		Height (in inches)	
		A	B	C	
Q4SD				with base rails	without base rails
-X24	450	28.0	25.5	39.0	35.3
-X30	455	28.0	25.5	39.0	35.3
-X36	460	28.0	25.5	39.0	35.3
-X42	565	29.5	26.0	43.0	39.3
-X48	570	29.5	26.0	43.0	39.3
-X60	580	29.5	26.0	43.0	39.3

DIMENSIONS (Continued)

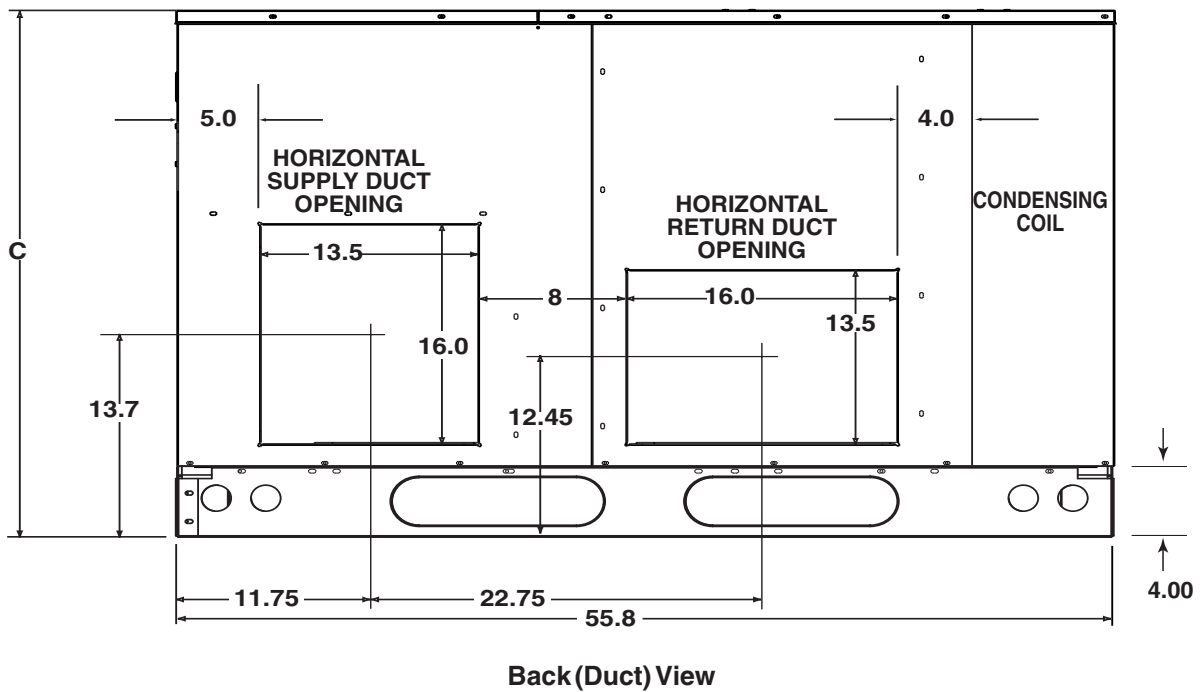
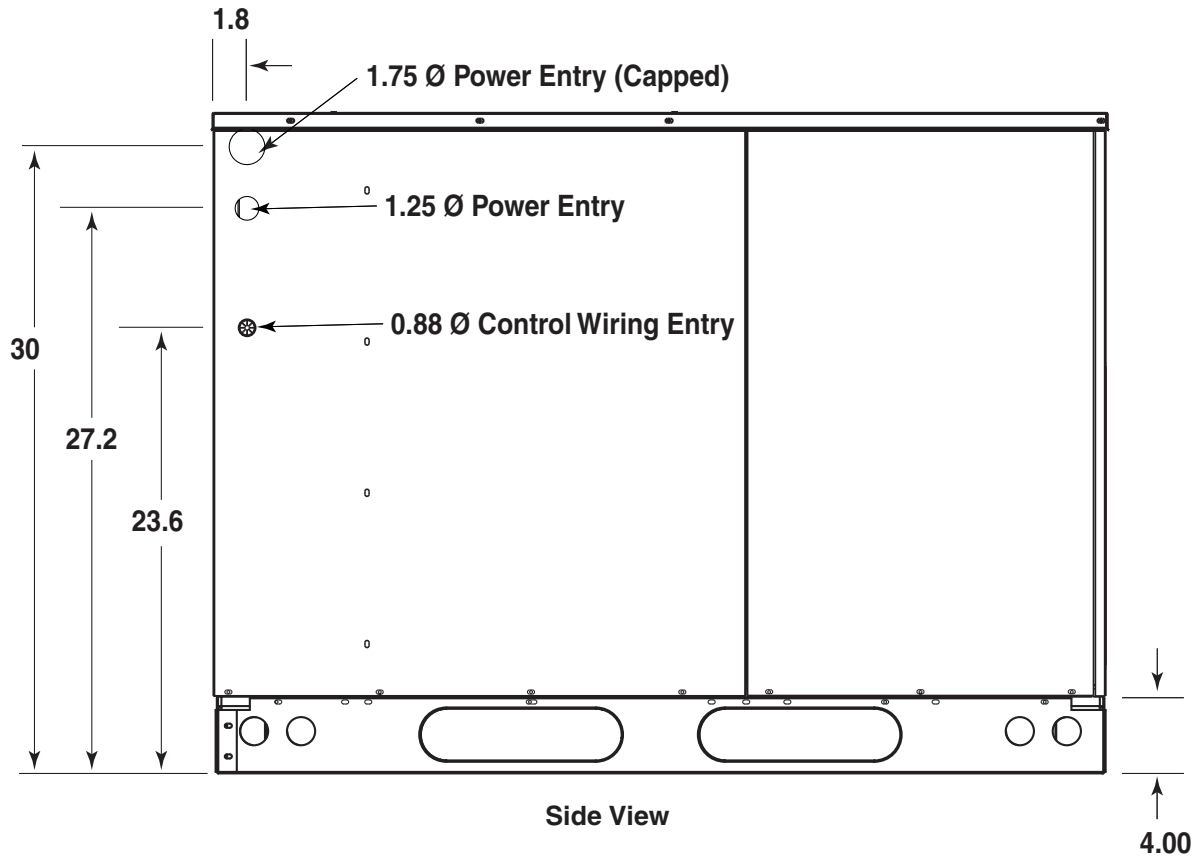

SPECIFICATIONS

Model Number	Q4SD					
	-X24K	-X30K	-X36K	-X42K	-X48K	-X60K
Performance						
Capacity - Heating BTUH	22,000	29,800	33,500	41,600	45,000	51,000
Efficiency - HSPF	7.7	7.7	7.7	7.7	7.7	7.7
Capacity - Cooling BTUH	24,000	27,500	34,800	41,000	46,000	55,500
Efficiency - SEER	13.00	13.00	13.00	13.00	13.00	13.00
EER (Btuh/watt)	11.0	11.0	11.0	11.0	11.0	11.0
Electrical Rating - 60 Hz						
Phase	1	1	1	1	1	1
Operating Voltage Range	187-253	187-253	187-253	187-253	187-253	187-253
Compressor Data						
Volts	208-230	208-230	208-230	208-230	208-230	208-230
Rated Load Amps	12.1	15.0	17.9	20.0	23.6	28.0
Lock Rotor Amps	54	72.5	88	104	137	148
Indoor Blower						
Type	Var. Sp.	Var. Sp.	Var. Sp.	Var. Sp.	Var. Sp.	Var. Sp.
Motor HP	1/2	1/2	1/2	3/4	3/4	3/4
Motor RPM Range	490-740	490-740	490-740	645-950	645-950	645-950
Motor - Amps	4.3	4.3	4.3	6.8	6.8	6.8
Outdoor Fan						
Motor - HP / RPM	1/4 - 1100	1/4 - 1100	1/4 - 1100	1/4 - 1100	1/4 - 1100	1/3 - 1100
Motor - Amps	1.2	1.2	1.2	1.2	1.2	1.5
Fan Diameter / CFM	20 / 3800	20 / 3800	20 / 3800	20 / 3800	20 / 3800	20 / 4000
Refrigerant Charge - Oz.	120	114	127	283	293	224
Net Weight lbs.	450	455	460	565	570	580
Shipping weight lbs.	460	465	470	575	580	590

BLOWER PERFORMANCE

Basic Air-Flow Settings

1/2 HP Motor							3/4 HP Motor								
CFM	Switch				Nominal			CFM	Switch				Nominal		
	1	2	3	4	2.0	2.5	3.0		1	2	3	4	3.5	4.0	5.0
490	0	0	0	1				880	0	0	0	1			
575	0	0	0	0				975	0	0	0	0			
660	0	0	1	0				1080	0	0	1	0			
770	1	0	0	1				1125	1	0	0	1			
860	1	0	0	0				1265	1	0	0	0			
895	0	1	0	1				1390	0	1	0	1			
970	1	0	1	0				1455	1	0	1	0			
1060	0	1	0	0				1590	0	1	0	0			
1145	1	1	0	1				1690	1	1	0	1			
1170	0	1	1	0				1785	0	1	1	0			
1350	1	1	0	0				1915	1	1	0	0			
1510	1	1	1	0				2125	1	1	1	0			

Note: 1=ON, 0=OFF

Air Flow Selection for Variable Speed Motors

Nominal KW	CFM	Switch Number							
		1	2	3	4	5	6	7	8
0-5	500					0	0		
6-10	700					1	0		
11-15	900					0	1		
16-20	1100					1	1		

Note: 1=ON, 0=OFF

Minimum Electric Heat Airflow (all models)

Delay Description	Switch Number							
	1	2	3	4	5	6	7	8
Delay A							0	0
Delay B							0	1
No Delay							1	0
De-Hum.							1	1

Note: 1=ON, 0=OFF

Delay Settings (all models)

HEATER APPLICATION MATRIX

Model Number	H3HK-005H-01	H3HK-008H-01	H3HK-010H-01	H3HK-015H-01	H3HK-020H-01	H3HK-015H-21	H3HK-020H-21
	917166	917167	917168	917169	917170	917172	917173
Q4S()-X24K	X	X	X(2)	X(2)	NA	X	NA
Q4S()-X30K	X	X	X(2)	X(2)	NA	X	NA
Q4S()-X36K	X	X	X(2)	X(2)	NA	X	NA
Q4S()-X42K	X(2)	X(2)	X(2)	X(3)	X(3)	X(1)	X(1)
Q4S()-X48K	X(2)	X(2)	X(2)	X(3)	X(3)	X(1)	X(1)
Q4S()-X60K	X(2)	X(2)	X(2)	X(3)	X(3)	X(1)	X(1)

NA = Not Applicable.
 () = Number of internal circuit breaker kits required.

MODEL IDENTIFICATION CODE

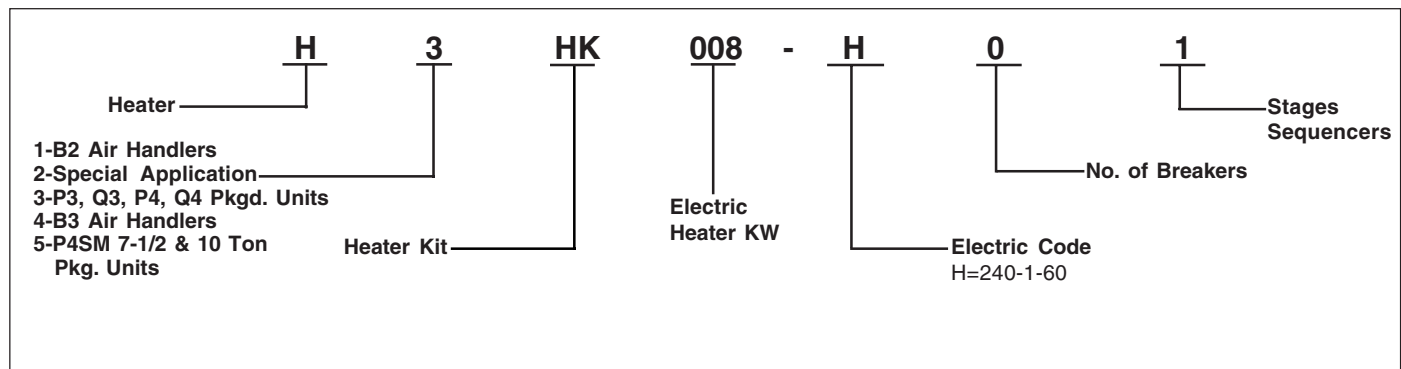

Q4 ACCESSORIES

Description	Part Number
Roof Curb (8")	547830
Roof Curb (14")	547831
Roof Curb (18")	547850
Roof Curb (24")	547851
Supply/return transition, 16"	547834
Supply/return transition, 18"	547835
Concentric diffuser, flush, 16"	547836
Concentric diffuser, flush, 18"	547837
Concentric diffuser, step down 16"	547838
Concentric diffuser, step down 18"	547839
HOOD TYPE HAIL GUARD 34" X 76" Q4SDX24, X30, X36	547846
HOOD TYPE HAIL GUARD 38" X 76" Q4SDX42, X48, X60	547847
CO2 sensors (special order)	547848
DUCT SMOKE DETECTOR PHOTO ELEC	547892
MULTI SIGNAL CONTROL	547893
SAMPLING TUBE ST3	547894
SAMPLING TUBE ST5	547895
Filter Rack, All Downflow Applications (not required with economizer)	547885
Filter Kit (not required with economizer) Q4SDX24, X30, X36	547888
Filter Kit (not required with economizer) Q4SDX42, X48, X60	547889
Universal Hard Start Kit	912933
Low Pressure Switch Kit	913551
High Pressure Switch Kit	913550
Low Ambient Kit	913549A
P-Trap Kit	913810
Outdoor Thermostat Kit	913852