

## iQ Drive™

### 23 SEER Residential System

#### Indoor Sections

**B5VM Series**  
**Variable Speed Air Handler**

**C5 Series**  
**Residential Indoor Coils with EXV**

#### FEATURES and BENEFITS

- **Durable, Attractive Cabinet** — Designed using galvanized steel. The door is also galvanized steel, with a polyester urethane finish. The 950 hour salt spray finish resists corrosion 50% better than comparable units. The plastic drain pan is corrosion-resistant.
- **Multi-poised** — Can be used in horizontal, upflow, downflow and vertical applications.
- **Increased Efficiencies** — Air conditioning efficiencies up to 23 SEER.
- **Variable Speed Motor** — Advanced technology allows for automatic selection of cooling airflows and heating airflows to match any application.
- **Quiet Blower Operation** — Extra quiet and smooth blower on and off cycles.
- **Reduced air stratification** — This results in improved air quality by optimizing humidity removal and filtration capabilities.
- **Ease-of-Service** — Plug-in wire connections and built-in filter rack makes the air handler easy to service.
- **Plug-in Heater Kits** — Available in 5 kw - 30 kw
- **Air Handler Control Board** — Controls time-sequencing of heat stages with field-selectable sequence timing.
- **Breaker Accessibility** — Breaker accessible from front of unit when heater is applied.
- **No Fasteners on Sides or Back** — Smooth surfaces for ease of installation.
- **Cabinet Insulation** — 1" insulation with an R-value of 4.2 contributes to quiet operation and prevents cabinet sweating in difficult applications.
- **Warranty** — Eight year limited all parts warranty, a major benefit to the consumer.

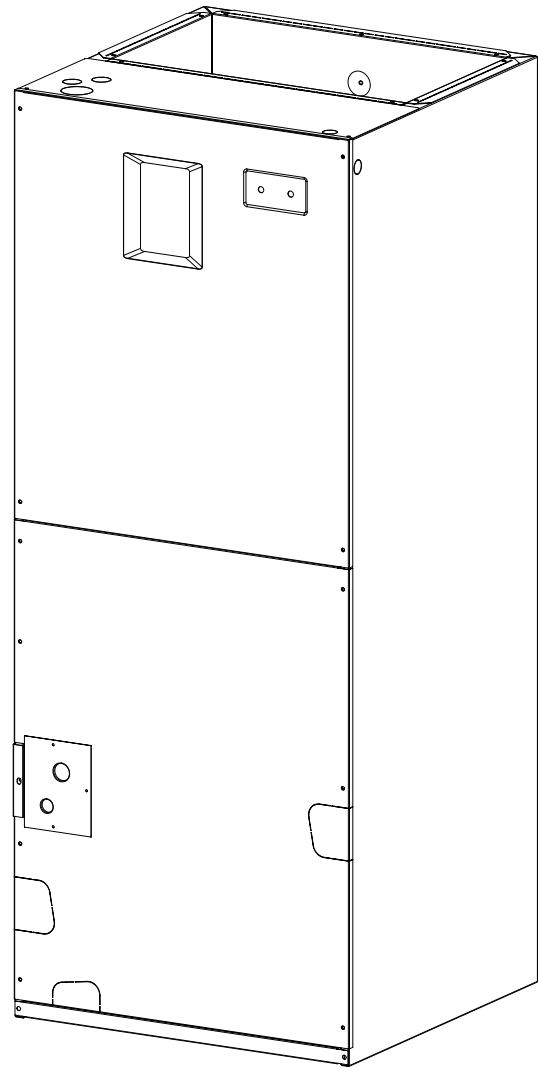

# B5 AIR HANDLER

## MODEL IDENTIFICATION CODE

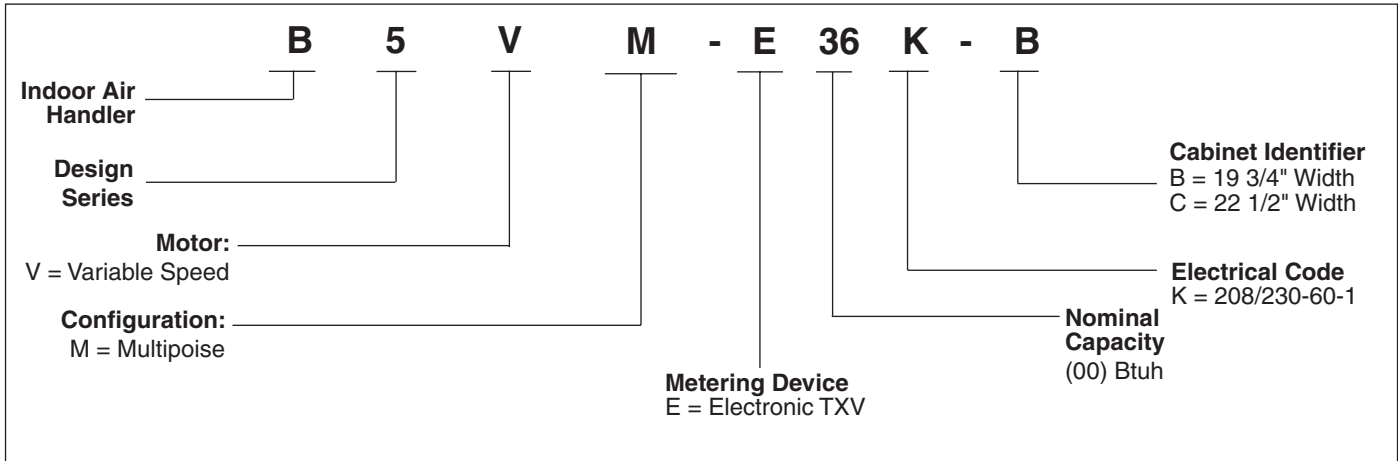

## DIMENSIONS

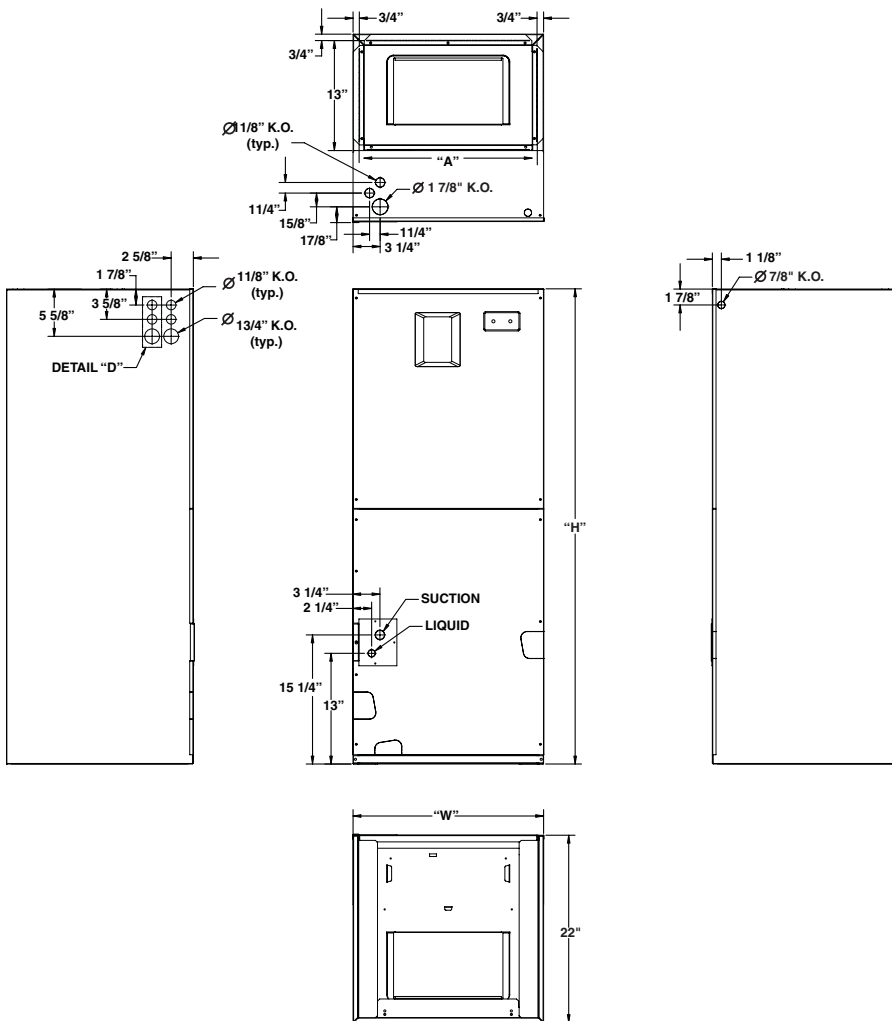

## SPECIFICATIONS

| Model Number   | *E36K-B         | *E48K-C     |
|--|-----------------|-------------|
| Nominal cooling capacity - BTUh <sup>1</sup>             | 36000           | 48000       |
| Metering Device  | EXV             | EXV         |
| Maximum Available Auxiliary Heat                         | 20              | 30          |
| Nominal Blower Size (Dia. x Width)                       | 11 x 8          | 11 x 10     |
| Motor Hp-speeds-type                                     | 1/2-VS          | 3/4-VS      |
| Filter Size (supplied internal filter rack) <sup>2</sup> | 18x20x1         | 20x20x1     |
| Approximate Shipping Weight, lbs                         | 114             | 154         |
| Height, "H", in.   | 49-5/16         | 55-15/16    |
| Width, "W", in.  | 19-11/16        | 22-7/16     |
| Supply Air Outlet Dimension, in.                         | 12-7/8 x 18-1/4 | 12-7/8 x 21 |
| Ref. Connection Sizes, in. (suc./liq.)                   | 7/8 - 3/8       | 7/8 - 3/8   |
| Range SCFM   | 500-1110        | 680-1455    |

<sup>1</sup> See current ARI Directory for certified combinations and ratings.

<sup>2</sup> Filter is not supplied with unit.

## ELECTRICAL DATA

|                    |         |      | Variable Speed Air Handler |           |           |                |                              |           |           |                |  |
|--------------------|---------|------|----------------------------|-----------|-----------|----------------|------------------------------|-----------|-----------|----------------|--|
|                    |         |      | Min. Circuit Ampacity      |           |           |                | Max. Over-Current Protection |           |           |                |  |
|                    |         |      | Circuit A                  | Circuit B | Circuit C | Single Circuit | Circuit A                    | Circuit B | Circuit C | Single Circuit |  |
| Model Number H6HK- | Voltage | KW   |                            |           |           |                |                              |           |           |                |  |
| 005H-XX            | 240     | 4.8  | -                          | -         | -         | 32.3           | -                            | -         | -         | 40             |  |
| 008H-XX            | 240     | 7.5  | -                          | -         | -         | 46.3           | -                            | -         | -         | 50             |  |
| 010H-XX            | 240     | 9.6  | -                          | -         | -         | 57.3           | -                            | -         | -         | 60             |  |
| 015H-XX            | 240     | 14.4 | 57.3                       | 25.0      | -         | 82.3           | 60                           | 30        | -         | 90             |  |
| 020H-XX            | 240     | 19.2 | 57.3                       | 50.0      | -         | 107.3          | 60                           | 60        | -         | 125            |  |
| 025H-XX            | 240     | 24.0 | 57.3                       | 50.0      | 25.0      | 132.3          | 60                           | 60        | 30        | 150            |  |
| 030H-XX            | 240     | 28.8 | 57.3                       | 50.0      | 50.0      | 157.3          | 60                           | 60        | 60        | 175            |  |
| 005H-XX            | 208     | 3.6  | -                          | -         | -         | 28.9           | -                            | -         | -         | 30             |  |
| 008H-XX            | 208     | 5.6  | -                          | -         | -         | 40.9           | -                            | -         | -         | 50             |  |
| 010H-XX            | 208     | 7.2  | -                          | -         | -         | 50.5           | -                            | -         | -         | 60             |  |
| 015H-XX            | 208     | 10.8 | 50.5                       | 21.6      | -         | 72.2           | 60                           | 25        | -         | 80             |  |
| 020H-XX            | 208     | 14.4 | 50.5                       | 43.3      | -         | 93.8           | 60                           | 50        | -         | 100            |  |
| 025H-XX            | 208     | 18.0 | 50.5                       | 43.3      | 21.6      | 115.4          | 60                           | 50        | 25        | 125            |  |
| 030H-XX            | 208     | 21.6 | 50.5                       | 43.3      | 43.3      | 137.1          | 60                           | 50        | 50        | 150            |  |

## ACCESSORIES

| Accessory Kit Description                         | Cabinet Size |   | Order Number |
|---|--------------|---|--------------|
|   | B            | C |              |
| Down-flow adaptor kit                             | X            |   | 919321       |
|   |              | X | 919322       |
| Single circuit adaptor for 2 circuit breakers     | X            | X | 913874       |
| Single circuit adaptor for 3 circuit breakers     | n/a          | X | 913556       |
| Horizontal conversion kit for vertical-only units | X            |   | 919405       |
|   |              | X | 914730       |

### 240V Single-Phase Heater Kit Application

| Nominal KW | Matched Units |       | Order Number          |                          |
|------------|---------------|-------|-----------------------|--------------------------|
|            | 36K-B         | 48K-C | With Circuit Breakers | Without Circuit Breakers |
| 5          | X             | X     | 904407                | 904406                   |
| 8          | X             | X     | 904409                | 904408                   |
| 10         | X             | X     | 904412                | 904411                   |
| 15         | X             | X     | 904414                | n/a                      |
| 20         | X             | X     | 904416                | n/a                      |
| 25         | n/a           | X     | 904417                | n/a                      |
| 30         | n/a           | X     | 904418                | n/a                      |

# C5 COIL

## MODEL IDENTIFICATION CODE

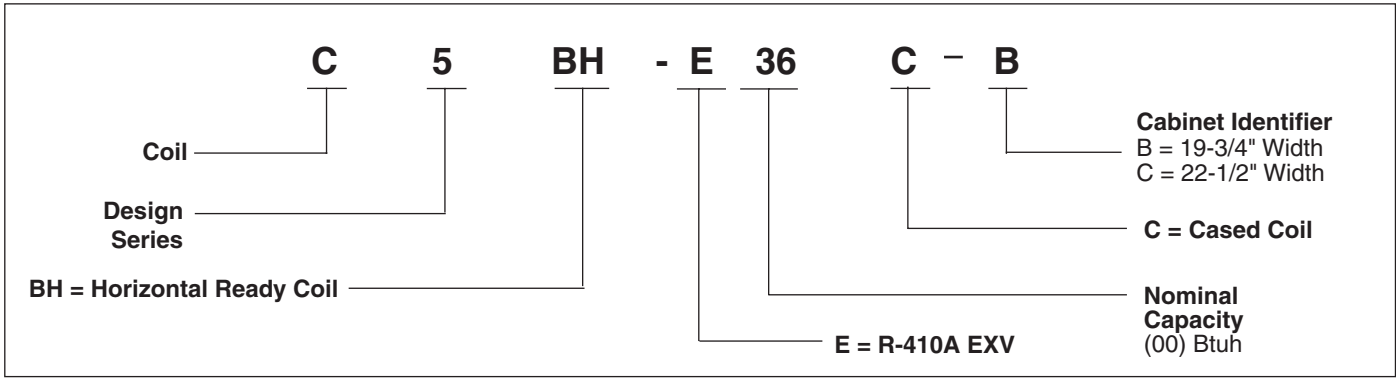

## COIL DATA TABLES

| Model C5BH                                 | E36-B           | E48-C  |
|--|-----------------|--------|
| Face Area (ft ^2)                          | 5.58            | 6.42   |
| Rows                                       | 3               | 3      |
| Fins per inch                              | 14              | 14     |
| Refrigerant Flow Control                   | EXV             | EXV    |
| Nominal Airflow (cfm)                      | 1200            | 1500   |
| Pressure drop at nominal airflow (in w.c.) | 0.21            | 0.30   |
| Connections:                               |                 |        |
| Inches                                     | Liquid Line 3/8 | 3/8    |
| Suction Line                               | 7/8             | 7/8    |
| Horizontal Kit                             | 919319          | 919320 |

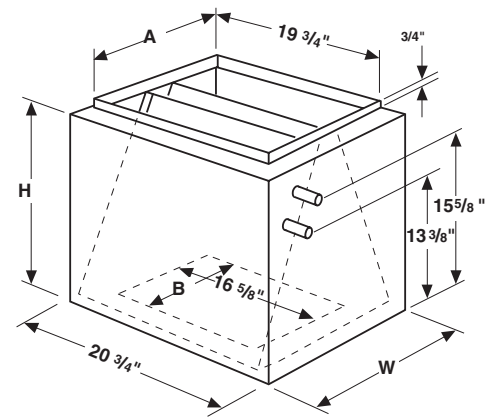

Figure 1. Cased Coil

### Cased Coil Dimensions

| Cabinet Identifier |            | Overall |    | Top Opening | Bottom Opening | Horizontal Drain Pan Extension |
|--------------------|------------|---------|----|-------------|----------------|--------------------------------|
|                    |            | W       | H  | A           | B              | C                              |
| <b>B</b>           | <b>E36</b> | 19 3/4  | 26 | 18 3/8      | 10 5/8         | 3 1/2                          |
| <b>C</b>           | <b>E48</b> | 22 1/2  | 29 | 21 1/8      | 13 5/8         | 4 1/2                          |

**NOTE:**  
 Requires IQ Drive Furnace Blower Conversion Kit.

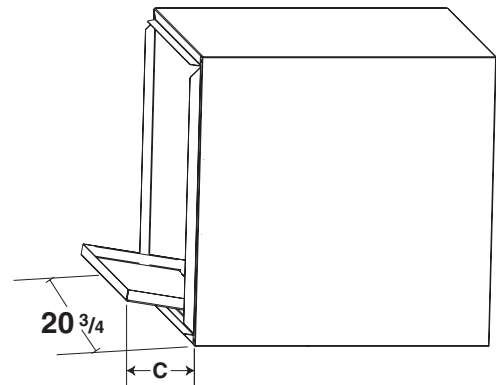

Figure 2. Horizontal Left Configuration with Drain Pan Extension



CERTIFICATION APPLIES ONLY WHEN THE COMPLETE SYSTEM IS LISTED WITH ARI



Trademark Tappan used under license.

296C-0506