

Split System Uncased Indoor Coils

Installation Instructions

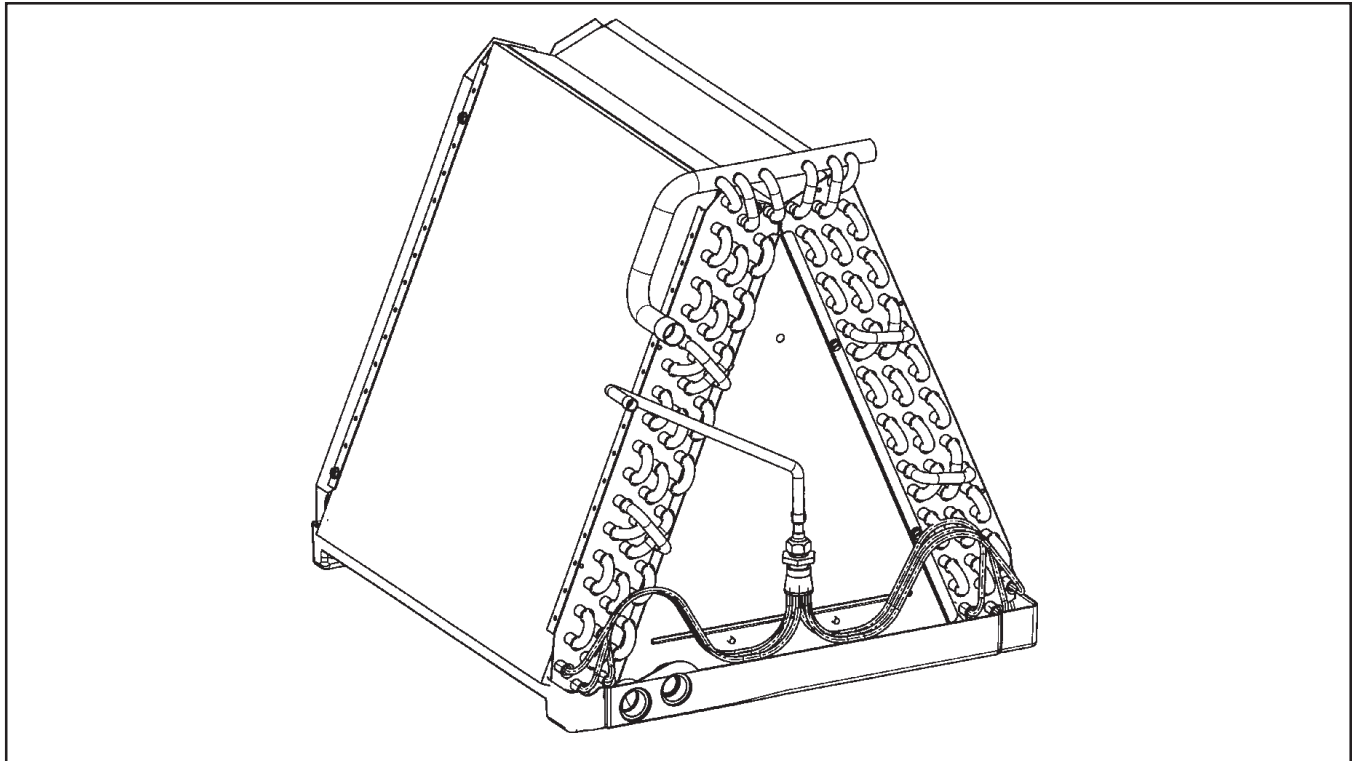

CAUTION:

Read the Installation Instructions supplied with furnace/air handler and observe all safety requirements outlined in instructions and/or furnace/air handler markings before proceeding with installation of the coil.

These instructions are primarily intended to assist qualified individuals experienced in the proper installation of this appliance. Some local and national codes require licensed installation/service personnel for this type of equipment. Read all instructions carefully before starting the installation.

1. GENERAL INFORMATION

These series coils are designed for upflow and downflow applications. They are equipped with brazing stub refrigerant connections for easy installation. Horizontal conversion kits are available. Refer to the Specifications Table below for more information.

Read the installation manual supplied with the outdoor unit for refrigerant line connection procedure, required line

sizes, and other information pertaining to the system installation.

1. Make certain that the air delivery of the furnace/air handler is adequate to handle the static pressure drop of the coil, filter, and duct work.
2. When applicable check the coil's orifice size and confirm that it is suitable for application with the intended outdoor unit.
3. Where precise forming of the refrigerant lines is required, a copper tubing bender designed for the size lines used is recommended. Avoid sharp bends and contact of the refrigerant lines with metal surfaces.
4. Refrigerant lines should be wrapped with pressure sensitive neoprene or other suitable material where they pass through the raw edges of holes.
5. Coil enclosure and suction line must be insulated.
6. Coil must be level for proper condensate drainage.

NOTE: Optional cooling/heating equipment must be properly sized and installed in accordance with the furnace manufacturer's specifications and approved recommendations. "Heating only" furnace air circulators may have to be replaced with multi-speed "Heating/Cooling" blowers to upgrade the air delivery (CFM) when an add-on coil is installed. Refer to Coil Specifications for recommended CFM and allow for pressure drop across the coil and filters.

2. COIL SPECIFICATIONS

Coil Model (1)	C3BA 024U-A	C3BA 030U-A	C3BA 036U-A	C3BA 043U-A	C3BA 030U-B	C3BA 036U-B	C3BM 036U-B	C3BA 042U-B	C3BA 048U-B	C3BA 048U-C	C3BA 060U-C
Nominal (2) Capacity BTUH	24,000	30,000	36,000	43,000	30,000	36,000	36,000	42,000	48,000	48,000	60,000
Nominal Airflow CFM (3)	900	1,125	1,200	1,400	1,100	1,350	1,350	1,500	1,500	1,600	1,800
Orifice Size (in.)	0.060	0.063	0.067	0.080	0.063	0.067	0.067	0.075	0.080	0.080	0.093
Width (in.) W	12 3/4	12 3/4	12 3/4	12 3/4	18 1/8	18 1/8	18 1/8	18 1/8	18 1/8	21	21
Height (in.) H	15	18 7/8	19 1/2	23 1/4	19 1/2	19 1/2	15	19 1/2	19 1/2	19 1/2	23 1/4
Connections (in.)											
Liquid Line	3/8	3/8	3/8	3/8	3/8	3/8	3/8	3/8	3/8	3/8	3/8
Suction Line	3/4	3/4	3/4	3/4	3/4	3/4	3/4	3/4	3/4	3/4	7/8
Horizontal Drain Kit	914633	917492	917492	914634	917492	917492	-	917492	917492	917492	914634

Coil Model (1)	C4BA- X24U-B	C4BA- X36U-B	C4BA- X48U-C	C4BA- X60U-C
Nominal (2) Capacity BTUH	24,000	36,000	48,000	60,000
Nominal Airflow CFM (3)	900	1200	1500	1800
Refrigerant Metering Device	TXV	TXV	TXV	TXV
Width (in.) W	18 1/8	18 1/8	21	21
Height (in.) H	19 1/2	25	28	28
Connections (in.)				
Liquid Line	3/8	3/8	3/8	3/8
Suction Line	3/4	7/8	7/8	7/8
Horizontal Drain Kit	917492	914634	917188	917188

1. Refer to sales specification sheets for Listed/Certified combinations of equipment and required accessories.
2. Refer to the current ARI Directory for certified ratings of split systems.
3. Based on a nominal 0.3" w.c. pressure drop across the coil.

3. COIL INSTALLATION

Upflow Furnace:

WARNING:

Electric furnaces may be connected to more than one supply circuit.

1. Disconnect all electrical power to the furnace.
2. If needed, make a plate to adapt the coil to the furnace/air handler air discharge opening.
3. Install the coil and level it as needed to allow proper condensate drainage.
4. Make a plenum to enclose the coil or drop the duct directly over it. Insulate as required. (See Figure 2)
5. Seal the enclosure as required to minimize air leakage.
6. Connect the refrigerant lines as outlined in the Refrigerant Lines section.

Downflow/Horizontal — These coils may be installed in downflow or horizontal applications. Installation of the coils in these applications only requires that the coil be securely mounted and that the proper horizontal drain kit be added. Refer to the Specifications section for the proper kit numbers.

NOTE: If the coil is installed horizontally, a drain kit must be used.

4. REFRIGERANT LINE CONNECTIONS

NOTE: Before proceeding with the connection of the refrigerant lines, confirm that the orifice size meets the requirements outlined in the outdoor unit installation manual. Factory installed orifice sizes are listed in the Specifications section. If the restrictor orifice must be replaced, follow the steps below:

NOTE: For coils with factory installed TXV valve proceed to step #7.

1. Loosen the orifice body halves by applying two wrenches and squeezing them together as shown in Figure 3, to turn the assembly nut counter-clockwise.
2. Continue to unscrew the assembly nut to separate it from the distributor body.
3. Insert a light-gauge wire hook between the distributor body and the restrictor orifice to lift the orifice out of the body. (See Figure 4) Carefully remove the restrictor orifice being careful not to scratch either part.
4. Check the actual size of the new orifice. The size is stamped on its side. Do not use pin gages to measure the orifice diameter.
5. Insert the new orifice in the distributor body, rounded end down. (See Figure 5)

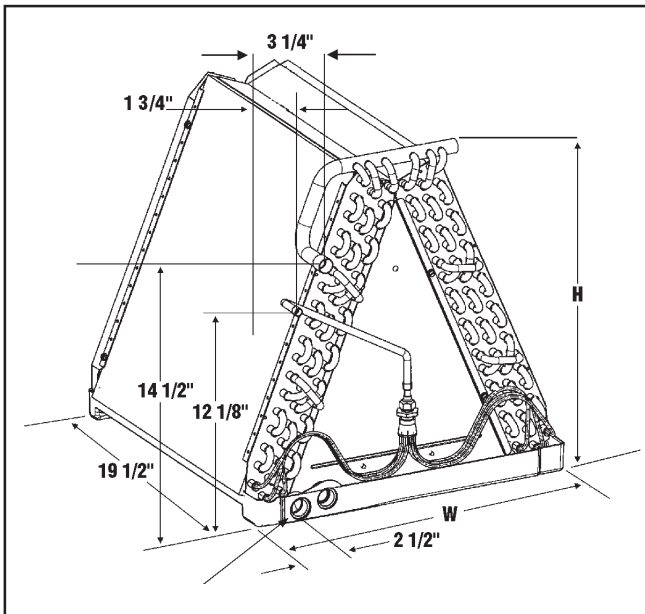

Figure 1. B & C Cabinet Coil

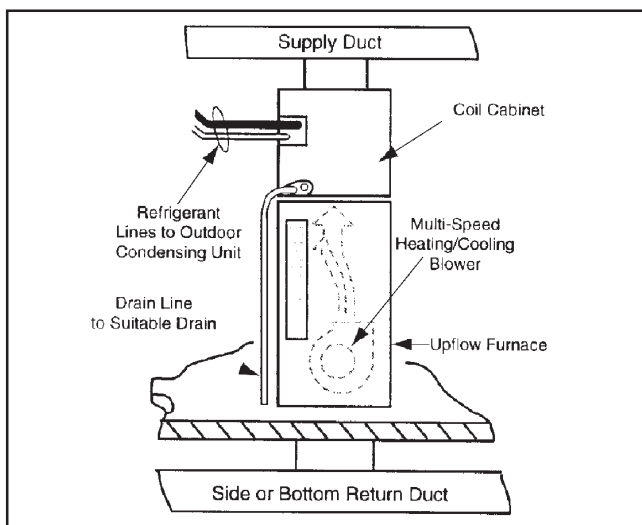

Figure 2

6. After installing the orifice in the distributor body, realign the assembly nut to the distributor body. Mark a line along both bodies after hand tightening and then tighten an additional 1/4 turn. Caution: Do not overtighten! The misalignment of the two lines will show how much the nut is tightened. If a torque wrench is used, tighten to 10-12 ft. lbs. or 14-16 Nm.
7. Remove the protective caps from the coil and refrigerant line set.
8. Cut the line set tubing to the proper length. Be sure that the tubing has been sized in accordance with the outdoor unit specifications.
9. Inspect both refrigerant lines. The ends of the lines must be round, clean, and free of any burrs.
10. Insert the line set tubes into the coil tube stubs until they bottom out.
11. Braze the individual connections with dry nitrogen flowing through the joints to eliminate internal oxidation and scaling.
12. Check the assembly for leaks with dry nitrogen.

5. COMPLETING THE INSTALLATION

⚠ CAUTION:

The indoor coil must be checked to ensure a level installation. Failure to do so may result in improper condensate disposal, causing structural damage, premature equipment failure, or possible personal injury.

Condensate Drain:

1. The coil condensate pan is furnished with 3/4" NPSC drain connections. Use a PVC or similar material fitting to attach the drain line to the pan. The fitting should be only hand tightened.
Overtightening may crack the drain pan and create a condensate leak.
2. Connect the drain line and run to a suitable drain avoiding sharp bends and pinching of the line. Install a condensate trap and prime with water.
3. During the system checkout, inspect the drain line and connections to verify proper condensate disposal.

Air Filter — Air filters are not provided as an integral part of this coil, however, a filter must be installed upstream of the coil and inspected frequently. When the filter becomes clogged with dust or lint, it should be replaced (disposable type) or cleaned (washable type). The filter should be inspected and replaced or cleaned at least twice during the year, generally at the start of each heating and cooling season.

Close-Off Plates and Panels — Install the necessary air close-off plates around the refrigerant lines and drain line where required. Reinstall all inner and outer panels of the furnace/air handler that were previously removed to install the indoor coil.

Refrigerant Charging — These indoor coils are not factory charged with refrigerant.

It will be necessary to evacuate the indoor coil and line set prior to charging. Refer to the outdoor unit installation manual for detailed charging instructions.

6. MAINTENANCE AND SERVICE

! WARNING:

Ensure that all electrical power to the furnace and outdoor (condensing) unit is off before performing any maintenance or service on the system.

To ensure optimum system performance and to minimize the possibility of equipment failure, the following periodic maintenance should be performed on the coil:

1. The air filter installed with the system should be checked and cleaned or replaced twice per year.
2. Check the coil, drain pan, and condensate drain line for cleanliness at the start of each heating and cooling season. Clean and remove any debris as required.

! CAUTION:

Do not operate the system without having a suitable filter in place in the return air duct system. Always replace the filter with the same size and type.

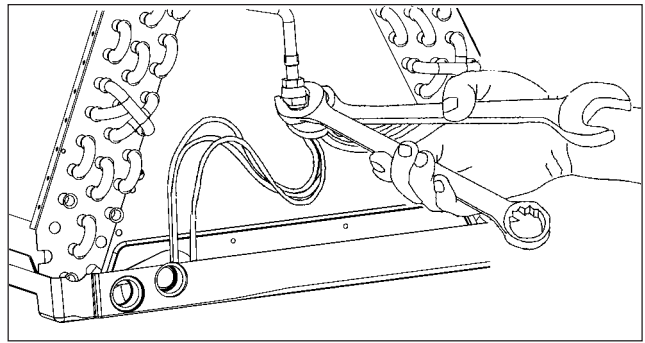

Figure 3. Wrenches on Distributor Body and Assembly Nut

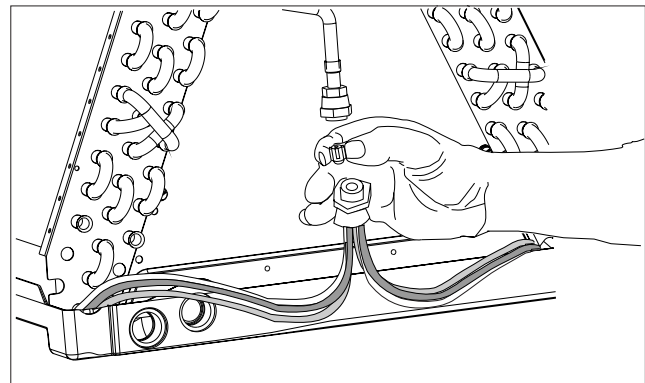

Figure 4. Removal of Orifice

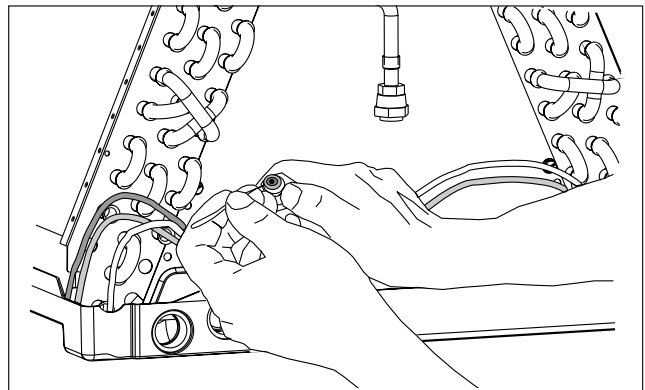

Figure 5. Restrictor Insertion in Distributor Body

INSTALLER: PLEASE LEAVE THESE INSTALLATION INSTRUCTIONS WITH THE HOMEOWNER



CERTIFICATION APPLIES ONLY
WHEN THE COMPLETE
SYSTEM IS LISTED
WITH ARI



7083730

7083730 (Replaces 707742C)

Specifications and illustrations subject to change
without notice and without incurring obligations.
Printed in U.S.A. (5/04)