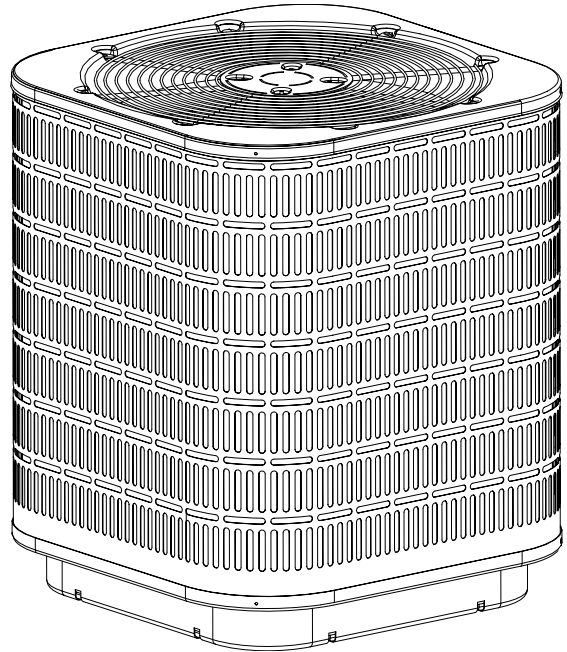

TECHNICAL SPECIFICATIONS

DS3BC Series Extra High Efficiency Air Conditioner 12/13 SEER Residential System 1-1/2 – 5 Ton Capacity

The DS3BC Series of air conditioners offers exceptional performance from a small, compact package. The unit, when combined with our engineered coils or air handlers, offers a full line of quality, split system cooling equipment. Units are ideally sized for slab or rooftop mounting in single, multifamily, and light commercial applications.

FEATURES and BENEFITS

- **Designed using galvanized steel** – with a polyester urethane coat finish. The 950 hour salt spray finish resists corrosion 50% better than comparable units.
- **Copper Tube / Aluminum Fin Coils** – Both indoor and outdoor coils are designed to optimize heat transfer, minimize size and cost, and increase durability and reliability.
- **Permanently Lubricated Motor** – A heavy duty PSC motor for long lasting reliability and quiet operation. Requires no maintenance and is completely protected from rain and snow.
- **Full Service Valves** – These brass valves are easily accessible and simplify servicing of the refrigeration system.
- **Steel Guard™** – Protects the unit coil from being damaged by balls, lawnmowers, hail, etc.
- **Removable Top Grille Assembly** – Allows ease of service from the top without disconnecting fan motor leads.
- **One Piece Top/Orifice** – Designed for maximum airflow and quiet operation.
- **2-1/2" Pedestal Base** – The sturdy base keeps the bottom of the coil out of harms way. Secondly, the base has weep holes along the edge to allow the water from rain to flow away from the unit.
- **Crankcase Heat** – Protection from liquid flood back and future compressor failures (not required on scroll compressor models).
- **Easy Compressor and Control Access** – Designed to make servicing easier for the contractor, access panels are provided to all controls and the compressor from the side of the unit.
- **6 Year Limited All Parts Warranty/10Year Parts Coverage on Compressor** – Has proven to be a major benefit to the consumer.



MODEL IDENTIFICATION CODES

EX: DS3BC-036KA

D	S	3	B	C	-	036	K	A
<p>D - Deluxe S - Air Conditioner T - Heat Pump</p> <p>Generation 1, 2, 3, etc.</p>			<p>Product Identifier</p> <p>BA = Braze 10 SEER BC = Braze 12/13 SEER BD = Braze 13/14 SEER</p>			<p>Nominal Capacity (000) BTU</p>	<p>Style A, B, etc. ...</p> <p>Electrical Code C = 208/230-60-3 K = 208/230-60-1</p>	

DIMENSIONS AIR CONDITIONER OUTDOOR SECTION

DS3BC-	018	024	030	036	042	048	060
H	22 1/2	26 1/2	30 1/2	34 1/2	30 1/2	34 1/2	42 1/2
W	22 1/2	22 1/2	22 1/2	22 1/2	30 1/2	30 1/2	30 1/2
D	22 1/2	22 1/2	22 1/2	22 1/2	30 1/2	30 1/2	30 1/2

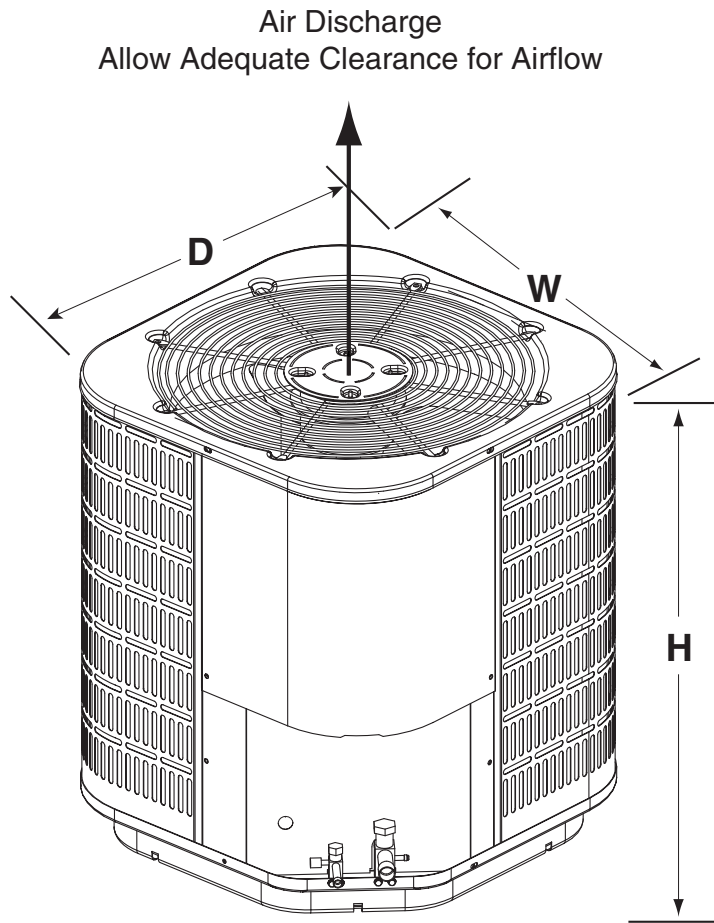

PHYSICAL AND ELECTRICAL SPECIFICATIONS / OUTDOOR UNITS

12/13 SEER — Extra High Efficiency — Single Phase

Model Number DS3BC-		018	024	030	036	042	048	060	
Electrical Data	Volts-Cycles-Phase (1)	208/230-60-1	208/230-60-1	208/230-60-1	208/230-60-1	208/230-60-1	208/230-60-1	208/230-60-1	
	Total Amps	10.3	12.8	14.7	17.8	19.8	21.8	29.4	
	Delay Fuse Max. (2)	20	25	30	35	40	45	60	
	Min. Circuit Ampacity	12.8	15.8	18.1	21.9	24.4	26.9	36.4	
Condenser Data	Coil	Area	8.2	9.9	11.5	13.2	17.7	20.3	25.4
		Rows-FPI	1-16	1-18	1-22	1-22	1-22	1-22	1-22
		Tube Dia	3/8" O.D.	3/8" O.D.	3/8" O.D.	3/8" O.D.	3/8" O.D.	3/8" O.D.	3/8" O.D.
	Fan Motor	Type	PSC	PSC	PSC	PSC	PSC	PSC	PSC
		Amps	0.34	0.67	1.1	1.4	1.4	1.4	1.4
		Watts-HP	37.3 - 1/20	74.6 - 1/10	93.3 - 1/8	186.5 - 1/4	186.5 - 1/4	186.5 - 1/4	186.5 - 1/4
	Fan Blade	Dia-# Blades	18"- 3	18"- 3	18"- 3	18"- 4	24"- 3	24"- 3	24"- 3
		SCFM	1630	1980	2345	2800	4000	4000	4000
	Compressor Data	RLA	10	12.1	13.6	16.4	18.4	20.4	28
		LRA	41	54	67	83	95	109	148
Refrigerant suction line O.D.(all length of liquid line are 3/8" O.D.)	0-24 ft.	5/8" (3)	3/4"	3/4"	3/4" (4)	7/8"	7/8"	7/8"	
	25-39 ft.	3/4"	3/4"	3/4"	7/8"	7/8"	7/8"	1-1/8" (5)	
	40-75 ft.	3/4"	3/4"	3/4"	7/8"	7/8"	7/8"	1-1/8" (5)	
Refrigerant charge (R-22) in ounces for outdoor unit, indoor unit and 15' lineset.		61	63	68	82	102	110	155	
Weight	Net	96	103.5	128	142	174	186	238	
Approximate (lbs.)	Ship	105	112.5	137	151	186	198	250	

* Values shown are most severe and may vary slightly depending on the make of the compressor supplied.

(1) Operating Voltage Range: 187v min. — 253v max.

(2) HACR Type Circuit Breakers may be used.

(3) Requires 3/4" to 5/8" reducer from unit to line.

(4) Requires 7/8" to 3/4" reducer from line to unit.

(5) Requires 7/8" to 1-1/8" reducer from line to unit.

ACCESSORIES - Condensing Unit

Start Assist Kit - 912933

Provides additional starting torque for the compressor motor when operating with low line voltage or high operating temperatures.

Fan Delay Kit

911758 - 80-second fan delay

COPPER WIRE SIZE — AWG (1% Voltage Drop)				
Supply Wire Length-Feet				Supply Circuit Ampacity
200	150	100	50	
6	8	10	14	15
4	6	8	12	20
4	6	8	10	25
4	4	6	10	30
3	4	6	8	35
3	4	6	8	40
2	3	4	6	45
2	3	4	6	50

Wire Size based on N.E.C. for 60° type copper conductors.

SYSTEM COOLING CAPACITIES

12 SEER — Extra High Efficiency — Single Phase

With this Coil					
Outdoor Unit Number DS3BC-	Indoor Unit Number C3BA-	BTUH	SEER	SCFM	Required Orifice (1)
018KA	024(U,C)-A+TDR (2)	17100	12	600	0.055
018KA	030(U,C)-A (2)	18000	12	600	0.055
018KA	030(U,C)-B+TDR	18000	12	600	0.055
024KA	030(U,C)-A/B	23600	12	800	0.060
030KA	036(U,C)-A/B (2)	28600	12	1025	0.065
036KA	043(U,C)-A+TDR	34600	12	1150	0.075
036KA	042(U,C)-B (2)	34600	12	1250	0.075
042KA	048(U,C)-B+TDR (2)	40000	12	1250	0.077
042KA	048(U,C)-C+TDR	40000	12	1250	0.077
048KA	050(C)-B	46000	12	1600	0.082
048KA	060(U,C)-C (2)	46000	12	1600	0.082
060KA	060(U,C)-C+TDR (2)	56000	12	1700	0.093

With this Air Handler					
Outdoor Unit Number DS3BC-	Indoor Unit Number B3B(M,V)-	BTUH	SEER	SCFM	Required Orifice (1)
018KA	024K-AB	17100	12	600	0.055
018KA	030K-(A,B)B	18000	12	600	0.055
024KA	030K-(A,B)B	23600	12	800	0.060
030KA	042K-BB	28600	12	875	0.065
036KA	042K-BB	34600	12	1250	0.075
042KA	048K-BB	40000	12	1425	0.077
048KA	060K-CB	46000	12	1730	0.082
060KA	066K-CB	56000	12	1600	0.099

(1) Orifice supplied with outdoor unit.
 (2) Available as horizontal coil.
See current ARI Directory for certified combinations and ratings.

13 SEER — Extra High Efficiency — Single Phase

With this Coil					
Outdoor Unit	Indoor Unit Number C3BA-	BTUH	SEER	SCFM	Orifice (1)
018KA	030(U,C)-B+TDR+VSB	18200	13	720	0.055
024KA	030(U,C)-B+VSB	24000	13	800	0.060
024KA	036(U,C)-B+VSB (2)	24000	13	800	0.060
030KA	036(U,C)-B+VSB (2)	29000	13	1060	0.065
036KA	042(U,C)-B+VSB (2)	35000	13	1185	0.075
042KA	048(U,C)-B+TDR+VSB (2)	40500	13	1185	0.077
042KA	048(U,C)-C+TDR+VSB	41000	13	1225	0.077
048KA	060(U,C)-C+VSB (2)	46500	13	1555	0.082
060KA	060(U,C)-C+TDR+VSB (2)	56000	13	1655	0.093

With this Air Handler					
Outdoor Unit	Indoor Unit Number B3B(M,V)	BTUH	SEER	SCFM	Orifice (1)
018KA	030K-B+VSB	18200	13	720	0.055
024KA	030K-B+VSB	24000	13	800	0.060
030KA	042K-B+VSB	29000	13	860	0.065
036KA	042K-B+VSB	35000	13	1185	0.075
042KA	048K-B+VSB	40500	13	1375	0.077
042KA	048K-C+VSB	41000	13	1465	0.077
048KA	060K-C+VSB	46500	13	1775	0.082
060KA	066K-C+VSB	56500	13	1665	0.099

With this Air Handler					
Outdoor Unit	Indoor Unit Number B3VM	BTUH	SEER	SCFM	Orifice (1)
018KA	036K-B	18200	13	720	0.055
024KA	036K-B	24000	13	800	0.060
030KA	048K-B	29000	13	860	0.065
036KA	048K-B	35000	13	1185	0.075
042KA	048K-B	40500	13	1375	0.077
042KA	048K-C	41000	13	1465	0.077
048KA	060K-C	46500	13	1775	0.082
060KA	066K-C	56500	13	1665	0.099

(1) Orifice supplied with outdoor unit.
 (2) Available as horizontal coil.
See current ARI Directory for certified combinations and ratings.



CERTIFICATION APPLIES ONLY WHEN THE COMPLETE SYSTEM IS LISTED WITH ARI